



# NYBORG - MAWENT



## CENTRIFUGAL FANS

Nyborg-Mawent S.A.  
ul. Ciepła 6, 82-200 Malbork, Polska

tel: +48 55 646 63 00  
fax: +48 55 646 63 09  
[www.nyborg-mawent.com](http://www.nyborg-mawent.com)  
[office@nyborg-mawent.com](mailto:office@nyborg-mawent.com)



## GENERAL INFORMATION

Construction of one-stream centrifugal fans is adjusted to work in difficult conditions of land and marine industry environment. All products and their equipment are produced according to actual EN norms as well as according to implemented quality norms ISO 9001:2008, ISO 14001:2004 and PN-N 18001:2004.

In standard the fan consists of steel and welded housing, impeller, motor pedestal and base frame equipped with vibration dampers. Presented flow parameters are calculated for medium with 20°C temperature and density 1,2 kg/m<sup>3</sup>.

All fans are intended for work in ambient temperature range -20°C-40°C; all other temperature ranges demand additional technical agreements.

Equipment in basic execution is intended for work with medium -10°C- 80°C. Fans equipped with cooling disc may work with agent up to 300°C, non-standard executions enable work up to 750°C.

Impellers produced by Nyborg-Mawent are balanced in G6,3 class or G2,5 on request. The fans comply with norms and requirements regarding vibration level according to ISO 14694:2003. Allowable vibration level is specified in fan's technical documentation. Each finished product is tested in terms of its work parameters.

## TYPES OF DRIVE



Direct drive (1) – impeller is mounted directly on motor's shaft; for horizontal and vertical work.

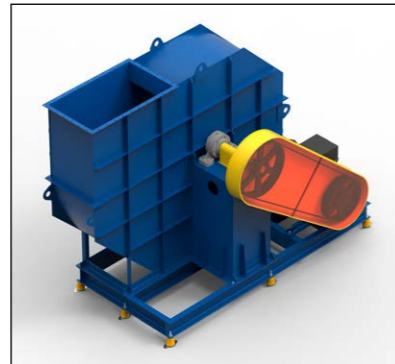

Indirect belt drive (2) – the fan is driven with motor by means of belts;



Indirect coupling drive (4) – the fan is driven with motor by means of coupling.

## TYPES OF DRIVE

Type of drive	Standard	Cooling disc	Insulation and cooling disc
NAP1	do +80°C	do +220°C *	do +250°C *
NAP2	do +100°C	do +300°C	do +300°C
NAP4	do +100°C	do +300°C	do +300°C

\*\*consultation with producer is required

Fans in execution for agent temperature up to 750°C are produced on special request.

## DIRECTION OF ROTATION

We assume two possible directions of rotation: RD (right) and LG (left) looking from motor's side. It refers to all types of drives.

## MOUNTING POSITIONS

It is given in degrees after direction of impeller rotation is specified. On customer's request other mounting positions are also produced.

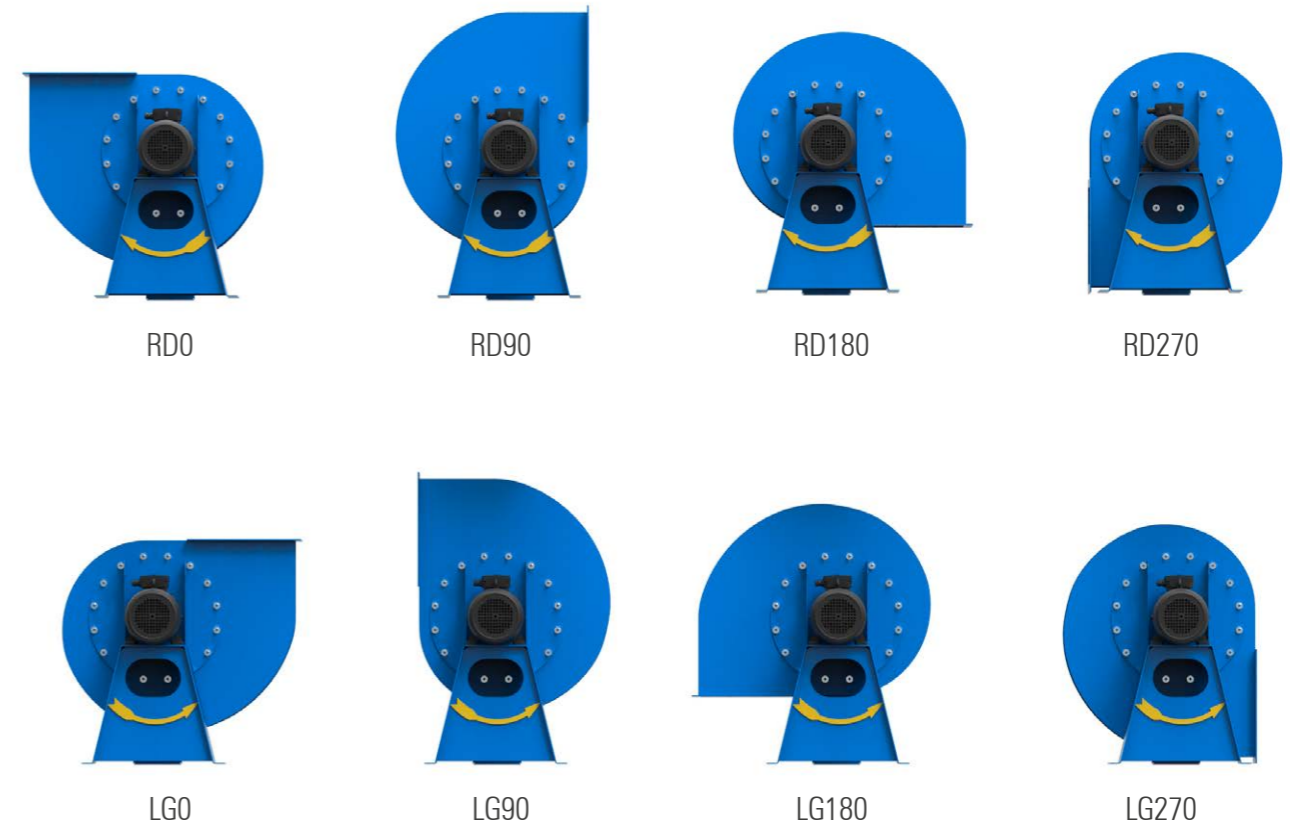

## ACOUSTICS

Acoustic measurements are made according to norm DIN 45635 page 1 "Machine's noise measurements", in accordance to DIN 45635, part 38.

It must be taken into account that final noise level is influenced by local conditions, ventilation installment elements as well as the way and quality of assembly. Incorrect fan selection and work outside selected work

point also affects the fan's noise level. In order to lower the noise we use additional equipment such as: silencers, acoustic insulations on the housing, propulsion or motor and sound-proof cabins. Nyborg-Mawent's fans are tested in our measurement laboratory with open outlet.

## DESIGN

### 1. HOUSING

Welded construction made of various types of steel or aluminium – depending on requirements and working conditions. Additionally it can be equipped with inspection hatch, drain, sealings, insulations etc.

### 2. IMPELLER

In standard it is made of ordinary steel, in special execution it can be made of stainless steel (AISI 316L /304) or aluminium. All impellers are statically and/or dynamically balanced according to norm BN-79/1380-13 in two accuracy classes - G6,3 and G2,5 according to PN-77/M-04000 equal to dynamic and static balancing.

- Standard – intended for clean air pressing (dust content must not exceed 0,3 g/m<sup>3</sup>)
- Special execution – intended for contaminated agent pressing (dust content must not exceed 3 g/m<sup>3</sup>)
- Conveying fans – can press the agent with maximum dust content 0,2kg/m<sup>3</sup>.

There is also a possibility to produce a specially designed impeller adjusted to required working point.

### 3. INLET CONE

Its design and fitting into impeller's inlet part influences the fan's efficiency. In Atex execution it is lined with brass.

### 4. SEALING

In standard execution fans are not equipped with any sealing of shaft's transition through the casing.

However for our customers' special requirements we use:

- Frictional sealing with the use of brass and plastic (simmerings);
- Labyrinth sealing which provides high efficiency during the fans' work;
- Brass or graphite sealings for temperatures <300°C.
- Special sealings for temperature up to 750 °C

It must be noted that none of above provides a 100% sealing.

### 5. BEARINGS

In construction of fans with indirect drives (2) and (4) the impeller is mounted on the shaft embedded on rolling bearings. We use two types of bearings: ball and barrel.

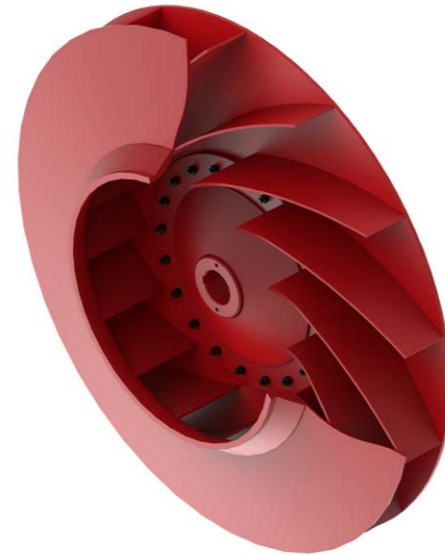

Example of impeller

Bearings can work in maximum temperature of 80°C. The bearings as well as their casings are greased with certified greases dedicated by their producers. Using an appropriate quality greases ensures a long term and failure-free operation of bearing gears. In standard constructions we use bearings of world-renowned producers for mechanical sizes from 60 to 190.

### 6. COUPLINGS

In fans with coupling drive we use claw and rubber couplings of world-renowned producers

### 7. MOTORS

We use 3-phase induction motors from Polish and foreign producers with cage impellers in IP55 execution.

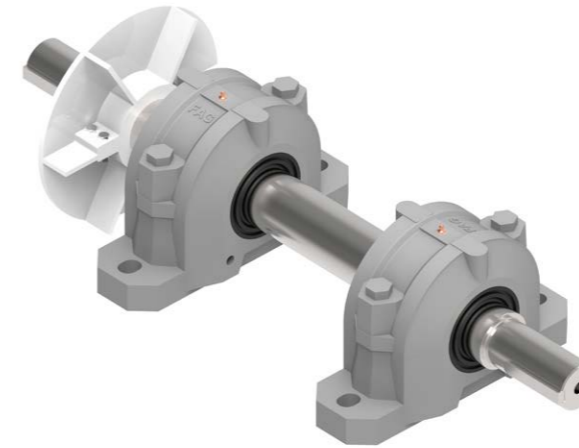

Example of bearings from FAG

Usually we use motors of following classes:

- • IE2 – high efficiency motors
- • IE3 – the highest (premium) level of efficiency.



Example of coupling from ROTEX

Purchased motors can be ready to work with frequency converter. Additionally they can be equipped with encoder, PTC, vibration and temperature sensors and heaters.

In the case when ambient temperature is higher than 40°C, the power drop must be taken into account, therefore adequately higher power of motor must be selected.

For fans in explosion proof execution we use Atex certified motors.

### 8. FRAME

Its main task is to increase the stiffness and durability of the fan.

Additional advantages are as follows:

- • Easy mounting on steel constructions;
- • No need of expensive fundaments building.

In order to stabilize the fan's work and minimize the vibration occurrence we use base frames equipped with a set of vibration dampers. In this arrangement the fan is screwed into intermediate frame which hides the vibration dampers underneath. Stiff frame construction together with well selected vibration dampers provide appropriate amortization and insulation between the fan and the fundament. Size, quantity and type of vibration dampers are selected on the basis of system's static load. Example of the base frame with vibration dampers.

### 9. THERMO-ACOUSTIC INSULATION

In the case of noise limitation to the required level we make the insulation of casing, which also functions as thermal protection. Our insulation is made of low conductance mineral wool with high resistance against steam diffusion and soundproof properties.

Thermo-acoustic insulation can be produced in a few options:

- Thermo-acoustic insulation of impeller;
- Acoustic insulation of propulsion, electric motor and the base-frame of the fan.

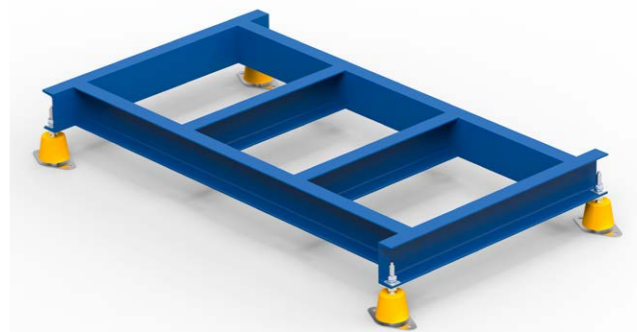

Przykładowa rama wentylatora z wibroizolatorami

### 10. FAN PARAMETERS' MONITORING

Depending on the function and weight of the fan in the installment, an appropriate monitoring of work should be provided.

Our fans can be equipped with:

- Vibration sensors for housing;
- Vibration and temperature sensors for bearings;
- Temperature sensors for bearings and motor's winding.

### 11. COOLING DISC

It is mounted on the shaft in fans intended to press the agent with temperature higher than 80°C. Its construction provides an effective insulation of bearings from heat influence area, which allows for bearings' gear safe work.

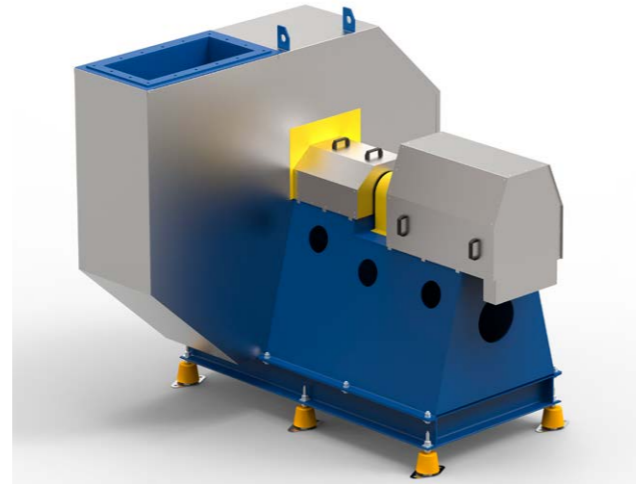

Przykładowa izolacja akustyczna

### 12. ANTI-CORROSION PROTECTION

Our fans in standard execution are painted with C3 set of paints up to 80°C, blue color RAL5009.

On customer's request change of painting or hot deep galvanizing is possible.

Additionally as anti-corrosion protection we use acid treatment, glass blasting or passivation; painting in C5-I corrosive atmosphere is also an option.

In non-standard executions appropriate painting layers are selected. There also exists painting for temperature up to 300°C. For explosion-proof fans in Atex execution we use anti-electrostatic paints.

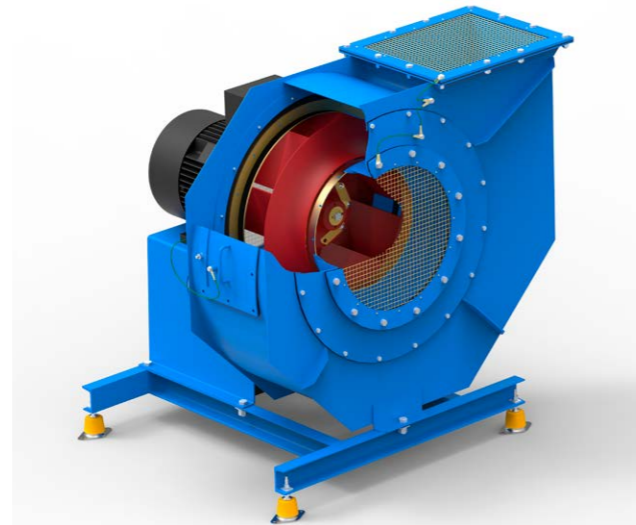

## CERTIFICATES

Using its years of experience as well as modern technologies Nyborg-Mawent S.A. guarantees high quality, durability and declared flow parameters of its products. Thanks to constant aspiration for excellence, the Company confirmed the efficiency of management system with accomplishment of Integrated Management System Certificate for accordance to the norms:

- ISO 9001:2008 – Quality Management System;
  - ISO 14001:2004 – Environment Management System;
  - PN-N 18001:2004 – Industrial Safety Management System.
- ATEX certificate for explosion-proof products;  
Special executions accordant to the requirements of Classification Societies.



## CLASSIFICATION SOCIETIES

- Requirements of individual Societies differ from one another in their approach to tests preparation and their assessments. For the maintenance of equipment correct production standard, it is fundamental to determine the Customer's and given Qualification Society requirements at the beginning of order's realization. Acknowledgement of Certificate after each survey is the confirmation of high quality and durability of the product.
- There is also a possibility to execute required tests of a finished product in the presence of end Customer, which ultimately confirms correct selection of fan's parameters and construction in relation to Client's requirements.
- DNV GL – Det Norske Veritas / Germanischer Lloyd
- LRS – Lloyd's Register of Shipping
- ABS – American Bureau of Shipping
- BV – Bureau Veritas
- CCS – Chinese Certification Society
- KR – Korean Register of Shipping
- PRS – Polish Register of Shipping
- TUV

And many more.

# NYBORG - MAWENT



Nyborg-Mawent S.A.  
ul. Ciepła 6, 82-200 Malbork, Polska

tel: +48 55 646 63 00  
fax: +48 55 646 63 09  
[www.nyborg-mawent.com](http://www.nyborg-mawent.com)  
[office@nyborg-mawent.com](mailto:office@nyborg-mawent.com)